

LOW COST CONTROL ELECTRONICS

LCCE & SECOND GENERATION LCCE (LCCE-2)

- 100W of output power at your fingertips
- Cooler agnostic, applicable to other devices

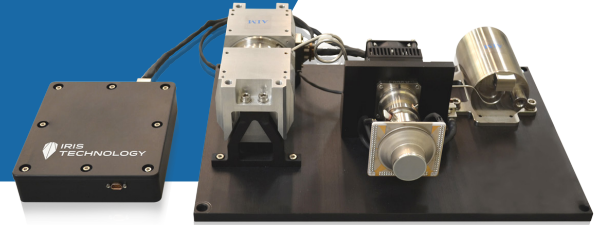

COMPACT, PLUG AND PLAY, RADHARD TECHNOLOGY FOR MULTI-PURPOSE CONTROL.

The Low-Cost Control Electronics (LCCE) is a radiation-hard, space qualified set of control electronics developed under AFRL and NASA SBIRs, initially designed to drive microsatellites space-based cryocooler systems supporting thermal imaging systems. The LCCE has two motor drives and temperature sensors, and is cooler agnostic, allowing it to be integrated with cryocoolers from multiple manufacturers.

In addition to basic cryocooler control functionality, the LCCE-2 adds an input ripple filter (IRF) and vibration control. The IRF reduces noise perturbation to the input power bus, reducing conducted emissions. The vibration control provides 5-harmonic vibration analysis between the accelerometer or force transducer and the compressor, adjusting the voltage and providing image stabilization.

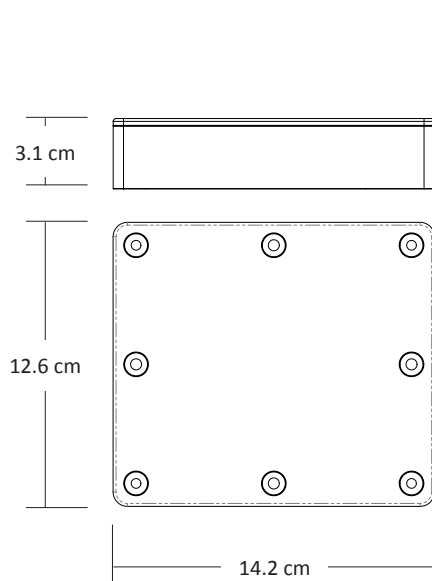

LCCE UNIT DIMENSIONS

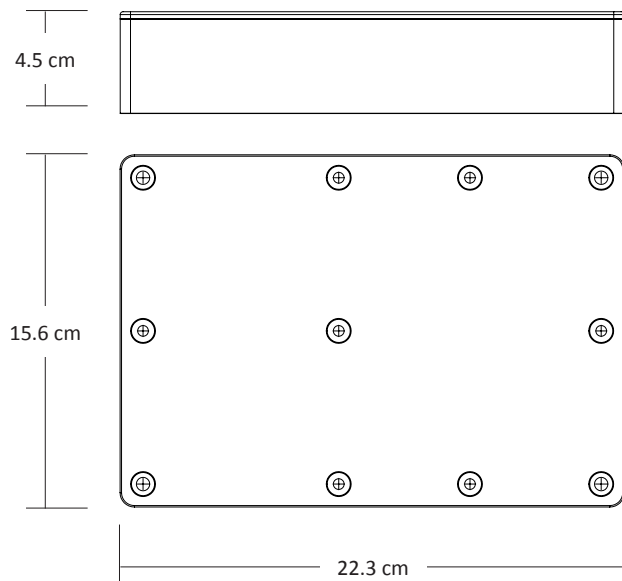

LCCE-2 UNIT DIMENSIONS

LOW COST CONTROL ELECTRONICS LCCE & LCCE-2

The LCCE and LCCE-2 were specifically designed to support a wide range of linear cryocoolers, from various manufacturers, at the nominal output power point of 100W. The LCCE and LCCE-2 are designed to tolerate radiation levels up to 100 krad. The LCCE accepts a DC input voltage from 22 to 35V and provides power conversion at 90% efficiency at rated power, while the LCCE-2 provides the same input voltage range at 85% efficiency at rated power. The LCCE-2 currently accepts a vibration signal from an Endevco 7703A-1000 accelerometer, and the input circuitry is easily adjustable to accept other accelerometer outputs.

The Iris Technology LCCE and LCCE-2 both represent FPGA based general purpose, radiation hardened platforms for the control of a variety of device types such as motors, actuators, solar power / battery charging systems, and optical bench thermal stabilization.

	Low Cost Control Electronics (LCCE)	2nd Generation LCCE (LCCE-2)
	100W	
GENERAL		
Application	Low Cost Space	Low Cost Space
# of Motors	2	2
PHYSICAL		
Mass	750 grams	1700 grams
Volume (cm)	12.6 x 14.2 x 3.1	15.6 x 22.3 x 4.5
POWER		
Input Voltage (V_{DC})	22 to 37	22 to 37
Total Output Power (W_{AC})	100	100
TEMPERATURE TELEMETRY		
# of Temp. Sensors	2	2
ADVANCED FEATURES		
Vibration Control	No	Yes
Input Ripple Filter	No	Yes / Optional
TRL Level	6	6